

Portable Phlegm Suction Unit

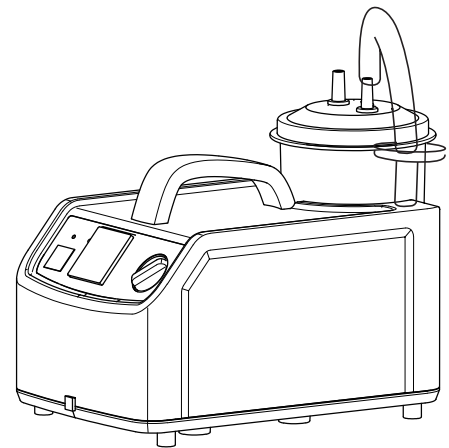

User's Manual



Please read the user's manual closely before using!

TABLE OF CONTENTS

- Product Features.....1
- Installing and Commissioning2
- Application and Maintenance 5
- Precautions8

8. Symbols

Symbols	Meaning	Symbols	Meaning
~	Alternating current	⚠	Consult the manual
○	OFF		ON

Application and Maintenance

1.Usage of battery

- Please check the internal battery if it is charged fully before using.
- Connect the power cord to a properly grounded AC outlet the charging light is bright shows the power supply and charges internal battery. The charging light gleams to mean the battery charging fully.
- Break net power, then use the internal battery.
- The internal battery shall be charged fully about 5 hr when it was been used up (the red light is bright). The internal used battery is charged according to residual power capacity in order to power capacity is full.
- The internal battery shall be charged and discharged once a month to maintain if it was not use for a long time.

△Note:
The unit has internal charger and shall be not used any other specification battery. The battery shall be not used over30minutes once.

2.The power for car lighter (DC 12V)

- Attach car lighter plug to the connector in the back of the unit and insert the car lighter cord to the socket when the unit was used to in patient transport. The light of car lighter is bright to mean that the DC power supply.

3.Changing air filter

- It is required to change air filter with the one produced by us in case of foam or dusts fully accumulated in the air filter, which leads to gradually darkening of the color of filter diaphragm and obviously reducing or even disappearing of suction force at the inlet of tube while the negative pressure indicated on the vacuum meter climbs up to 0.04 MPa or more.

△Note ①:The suction force will diminish or disappear, and the negative pressure ascend if the overflow device is closed, and the tube blocked in the process of application. Please refer to "trouble Shooting".

△Note ②:Necessary to frequently change air filter and destroy it centrally.

Product Features

1.General

phlegm suction unit is a novel, portable, AC/DC powered medical suction, which is suitable to use by the patient who has difficulty in phlegm removal due to illness, coma and operation, as well as for aspirating such liquid as pus and blood during the clinical practice. It is the commonly applied medical device in the emergency room, operation room, and for nursing in sickroom and health care in patient transport and place without AC/DC.

2.tructure & Working Principle

- Oil free lubrication pump to keep the environment from being polluted by the oil mist.
- Low noise.
- Square negative pressure meter, and plastic cover.
- No any positive pressure to be generated during running, to ensure reliable and safe operation.
- Negative pressure regulating system can be adjusted steplessly .Small in size, light in weight and portable.
- Supplied with three kind of power supply: AC, external DC. and internal battery, continuous movement time≥0.5 hr when fully charged, rechargeable, attach the unit to the car lighter (DC 12V) by wire when use on the vehicles such as ambulance.
- Charge method is constant current, and integral trickle type. When plugged into AC power, the internal battery maintenance control system will bright the battery to full charge, illuminating the green light on the unit.
- The operating principle diagram shown as follows:

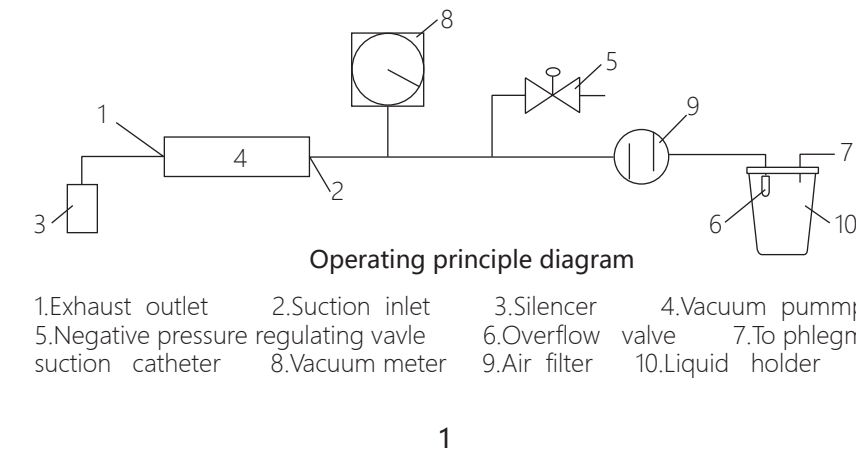

3. Main Technical Performances

- ① High negative pressure, low flow
- ② Power supply: AC120V±10% AC220VV±10% AC240V±10%
50Hz 60Hz DC12V
- ③ Input power: 65VA
- ④ Limit negative pressure: ≥0.075Mpa
- ⑤ Negative pressure regulating range: 0.02Mpa~limit negative pressrue
- ⑥ Suction rate: ≥ 15L/min
- ⑦ Liquid storage bottle: 1000mL/pc,1pc
- ⑧ Noise: ≤65dB(A)
- ⑨ Net Weight: 5.2Kg
- ⑩ Dimension: 330x187x300(mm)
- The apparatus is not suitable for use in the place with inflammable & explosive gas.
- Working system: short time running.
- Electric classification: Class II equipment,Type B applied part.

4. Normal Operating Conditions

- Ambient temperature: +5°C-+40°C
- Relative humidity: ≤80%
- Atmosphere pressure: 86kPa- 106kPa

Installing and Commissioning

1.Open Package Inspection

- The customer shall carefully inspect if the appearance of product is good, and the varieties & quantities of the attachments are in conformity with those as indicated in the attached list before installing and commissioning. Also, the customer shall timely notify the supplier or manufacturer of damage (s) if any.

2.Connecting (See Tube Connecting Diagram,with phlegm suction catheter temporarily not connected)

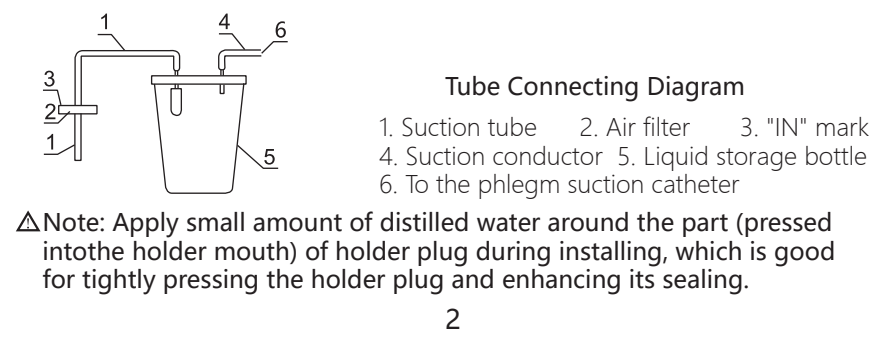

△Note: Apply small amount of distilled water around the part (pressed into the holder mouth) of holder plug during installing, which is good for tightly pressing the holder plug and enhancing its sealing.

Precautions

1. Transportation and storage conditios

- Ambient temperature: -40°C+55°C
- Relative humidity: ≤93%
- Atmosphere pressure: 70kPa- 106kPa

△Note:
It is required to store the aspirator in the well-ventilated room without corrosive gas, and avoid any violent shock while handling.

2. Electric and magnetic environment guidance in use

- The Portable Phlegm Suction Unit uses RF energy only for its internal function. Therefore, its RF emissions are very low and are not likely to cause any interference in nearby electronic equipment.
- The Portable Phlegm Suction Unit is suitable for use in all establishments, including domestic and those directly connected to the public low-voltage power supply network that supplies buildings used for domestic purposes.
- Due to the fact that the Electric Suction Apparatus contains no electronic control circuitry, they are deemed to fulfill the relevant immunity requirements without testing.
- The Portable Phlegm Suction Unit was not tested f or immunity to electromagnetic disturbances.

3. Electric systematic diagram

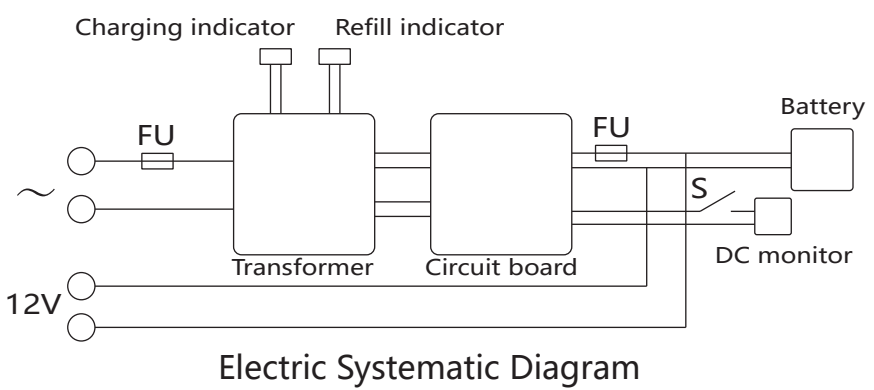

△ Note:
The dismantling & repair on the pump body if fault shall be conducted by the specialized worker. Please contact the manufacturer if required.

3. Power line connection

Connect the plug with the power source. Turn on the power supply, and the power indicator will illuminate.

△Note: The power plug is used for power shut-off, and the power socket shall be grounded reliably.

4. Connector inspection

- Turn tightly the negative pressure regulating valve clockwise, and block the air suction inlet with the finger or the rubber head of dropper, or fold up and hold the suction tube.
- Start the aspirator for running with no strange sound; the pointer of the vacuum meter will quickly reach up to the limit negative pressure. Release the air suction inlet, the pointer will return below0.02Mpa.If so,the connector can be regarded as being in good connection.
- Attach the phlegm suction catheter. The negative pressure in the negative pressure system shall be less than 0.06MPa at the time of attaching F6 suction catheter, less than 0.04 MPa when attaching FB suction catheter and less than 0.03 MPa when attaching F12 suction catheter. If so, the phlegm aspirator is considered as being in normal condition.

△ Note:Dredge the suction catheter if blocked as per the following method: Bend the suction conductor in "V" form (with no liquid in the holder), and release it to the original status when the negative pressure reaches up to the maximum value. Repeat this procedure several times till the catheter is not blocked.

5. Negative pressure regulating

- Block the suction inlet, open the aspirator switch and regulate the negative pressure valve, and the readings on the pressure meter shall be within 0.02 MPa~ limit negative pressure.
- Control the negative pressure as required for suction by means of the negative pressure valve at the time of clinical practice.
- Increase the negative pressure by turning the valve clockwise
- Reduce the negative pressure below 0.02 MPa prior to power shut-off.

6. Inspection & test on the overflow device

- Open the holder plug; clean up the valve mouth, and leveling the rubber valve clack on the float. The valve clack shall not be warped, bent and broken, but well connected with the float. The float shall be able to move freely in its support without any blockage.
- Lift the holder plug with hand to make the float contact the water surface perpendicularly gradually lower the holder cover to let the float rise.

4. Attachments

- Suction conductor (Φ7X12, length 2m): 1 PC
- Air filter: 2 PCS
- Fuse tube: F1.5AL250VΦ5X20 2 PCS
 F2AL250VΦ5X20 2 PCS
 T3.15AL250VΦ5X20 2 PCS
- Suction catheter: 1 pc respectively of child & adult
- Instruction manual: 1 pc

5. To dispose the castoff

The castoff should be disposed in accordance with all applicable government regulations.

All specifications and product configurations are subject to change without notification.

- Tighten the hold plug, attach the suction tube conductor at the inlet, and screw firmly the regulating valve, then, actuate the aspirator.
- Put the suction conductor into one clean water pail or attempt to simulate actual application to suction the liquid into the holder of the overflow device. As a result, the float will rise as the liquid level ascends until the valve is closed and suction stops automatically. The final position of liquid level depends on the suction process adopted.
- Release the regulating valve, set the aspirator switch off, open the holder plug and empty the liquid in the holder. The float shall be at the bottom of the support and the valve is in open status in case of re-screwing firmly the hold plug. If so, the overflow device is considered as being in normal condition, which can be used for clinical practice.

△Note:
① The liquid level still continuously ascends after the overflow device has been shut off, possibly due to:

- Residual negative pressure still in the holder.
- Valve mouth not fully closed.
- For Item (1), the liquid level in the holder will not ascend when the suction tube conductor is placed again into the liquid as suctioned, and for Item (2), the liquid level still ascends. Thus, it is required to observe carefully, and lift immediately the conductor out of the suctioned liquid when the holder is close to full, then, switch off the aspirator to stop suction, and examine the possible reason of the valve fault.

- The float is still adhered on the valve mouth as already closed by the float, possibly due to the negative pressure in the line. At this moment, release the regulating valve or shut off the aspirator (to release the negative pressure in the line), the float will descends from the valve mouth under the action of gravity. (It is forbidden to pull the float with hand, in order to avoid the rubber valve clack being separated from the float).

- After shut-off, release the negative pressure, then, open the holder plug;
- Never use the aspirator under the condition of the overflow device & the conductor dismantled.

7. Stop running

Turn off the aspirator switch, and pull the power plug out of the socket to shut off the power supply.

CE CERTIFİKA NUMARASI NO.: G2 18 01 96468 004



Jiangsu Shuangsheng Medical Appliance Co., Ltd. Dandong Industrial Park, Danyang City (No. 12 Lingkou 122 Highway Industrial Zone), 212353 Danyang, P.R.China(96468)

Prolinx GmbH
Brehmstr. 56 40239, Düsseldorf GERMANY
Tel: 0049 2131 4051968-0 Fax: 0049 2131 4051968-9

İTHALATÇI: ECE TIBBİ CİHAZLAR VE MEDİKAL SAN. TİC. A.Ş
Maltepe Mah. Hastane Sok. No: 6
Zeytinburnu – İstanbul - TÜRKİYE

MERKEZ: Maltepe Mah. Hastane Sok. No:6 Zeytinburnu / İSTANBUL	TEKNİK SERVİS: Telsiz Mah. Balıklı Kazığıçeme Yolu Sok. No:26/A Zeytinburnu / İSTANBUL
CİBALI: Zeyrek Mah. Atatürk Bulvarı 7/9 Fatih / İSTANBUL (Gök Ceşmî Binası Yanı)	MALTEPE: Bağbüyük Mah. Bağbüyük Cad. No:10/A-2 Maltepe / İSTANBUL
KARAGÜLLÜ: Molla Gürani Mah. Turgut Özal Millet Cad. Karagüllü Merkezî No: 84/2B25 Fatih / İSTANBUL	ANKARA: Balçelievler Mah. Şevket Süreyya Aydemir Sok. No:4/A Bahçelievler / ANKARA
BURSA: Demirtaşpaşa Mah. 2. Sabuncu Sok. No:32/A Osmangazi / BURSA	

www.respiroX.com.tr 444 78 96 www.ecemedikal.net